



# Customized Pergola

assembly guide manual



# SUMMARY

1. NECESSARY TOOLS.....	2
2. PROFILE MODELS FOR PERGOLAS.....	3
3. FACTORY METALON MODELS FOR PERGOLA.....	4
4. SUPPLIES AND ACCESSORIES.....	5
5. ASSEMBLY.....	6
1. Columns.....	6
2. Stringers.....	6
3. Cranes.....	8

Every work must have technical monitoring.  
For US Eco provides product warranty.  
For more information about the warranty see our website.

## 1. NECESSARY TOOLS

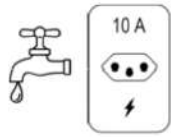

1. Water and energy



6. Drill set



2. Drills or type auger

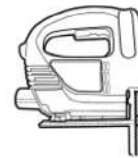

7. Hacksaw

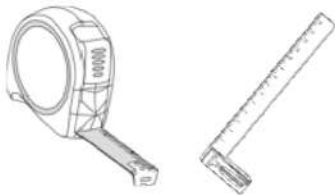

3. Measuring tape or square

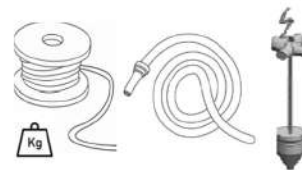

8. Iron plumb,  
level hose, line



4. Drill screwdriver

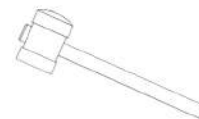

9. Rubber hammer

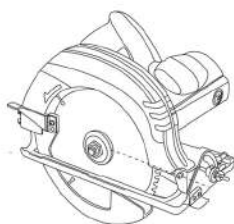

5. Circular saw

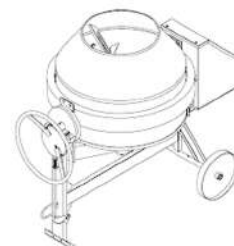

10. Concrete mixer or  
mass box

Note: for a proper workforce need to have basic knowledge level, plumb and square.

## 2. PROFILE MODELS FOR PERGOLAS



1. 3.5" x 3.5" column



2. 5" x 5" column



3. 8" x 8" column



4. 6" x 2.5" column

### 3. FACTORY METALON MODELS FOR PERGOLA

#### 1) 3" x 1.5" x 0.05"

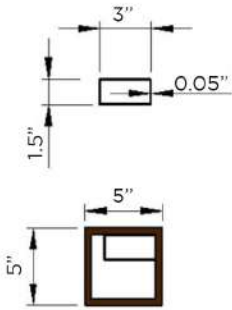

Metalon 3" x 1.5" x 0.05" used for the 5" x 5" column

Maximum free gap of 118" with overhang of 12.5 in length on each side.  
Maximum free gap of 102" with only one side of the eaves.

#### 2) 2.3" x 1.25" x 0.05"

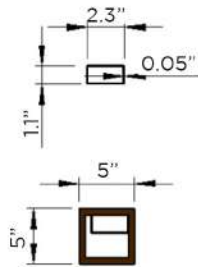

Metalon 2.3" x 1.1" x 0.04" used for the 5" x 5" column

Maximum free gap of 118" with overhang of 12.5 in length on each side.  
Maximum free gap of 102" with only one side of the eaves.

#### 3) 2" x 1.5" x 1" x 0.10"

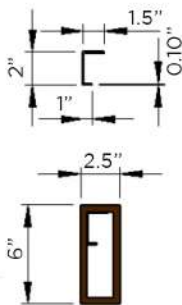

Metalon C 2" x 1.5" x 1" x 0.10" used for the 6" x 2.5" column

Maximum free gap of 118" with overhang of 12.5 in length on each side.  
Maximum free gap of 102" with only one side of the eaves.

## 4. SUPPLIES AND ACCESSORIES



1. Angle and plastic finishing



2. Biochromatized or stainless steel 0.1" x 1" CC screw



3. Bi-chromated or stainless steel 0.2" x 1" flanged screw



4. Biochromatized or stainless steel 0.2" x 1.5" DC screw



5. Lid applied 3.5" x 3.5"  
5" x 5"



6. Lid applied 6" x 2.5"



7. Plastic T

## 5. ASSEMBLY

### 1) Columns

Make sure the place where the pergola will be installed is flat. In this way the supports will be in the same measure and can be installed on land, floor or subfloor. For installation on land, it is essential to use a digger to make the holes where the columns will be buried, which must be buried at least 20", as shown in the image below:

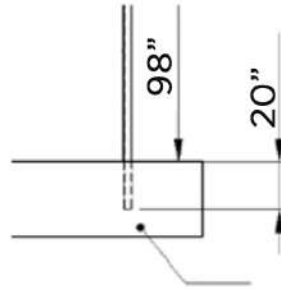

To install the pergola under the floor, use the L-shaped bracket, fixing it to the floor. Drill the hole in the platform, put the angle bracket on the platform and pass the screw, fitting the angle bracket and attaching it to the other side of the platform with the nut and washer.

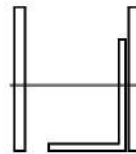

The choice of which column will be used will be requested by the customer. In the case of the use of 5" x 5" and 3.5" x 3.5" columns, they must contain metal or they must have lattice and be concreted. In the case of columns 8" x 8" these must have iron trusses and be concreted.



Armed ready column (5/16)  
3" x 5.5"



TB trellis 3"

### 2) Stringers

After choosing which column to use, choose which stringer to use. The fitting on the vertical column to accommodate the stringer must be in accordance with the dimension of the model of the chosen profile.

In the case of using a 6" x 2.5" column profile, the 5" x 5" or 8" x 8" mm profile must be fitted, as shown in the image below.

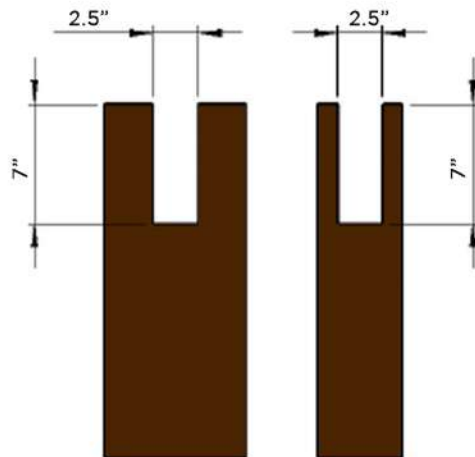

Factory metalon stringers and boards withstand a maximum of 118" of free gap, supported on two ends, respecting the rule of 12.5% of eaves spacing on both sides.

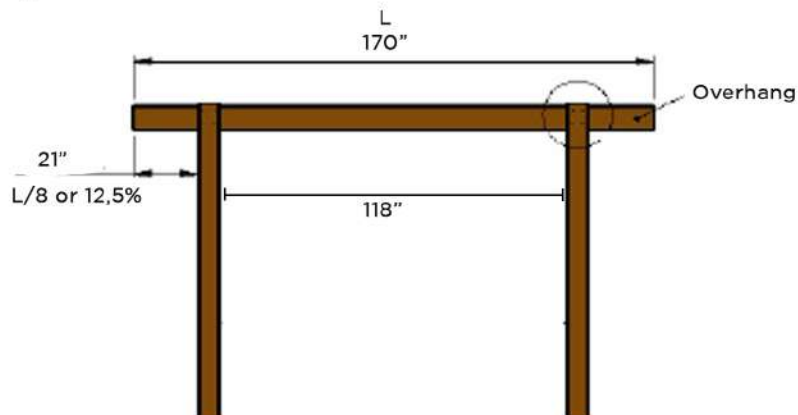

For pergolas that do not have space on both sides for equal distribution of the spacing of the eaves or pergolas against the wall, the free gap of stringer and boards must be a maximum of 102"

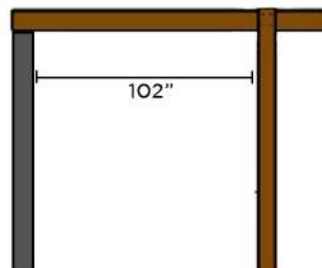

Attention: for free span measurements greater than that indicated for the 5" x 5", 6" x 2.5" and 3.5" x 3.5" stringers, a reinforced metalon must be used to withstand the effort of the free gap, which must be indicated by a responsible metallurgist.



The fixing of the 6" x 2.5" stringers is performed by means of 4 0.2" x 1.5" DC screws, as shown in the image below:

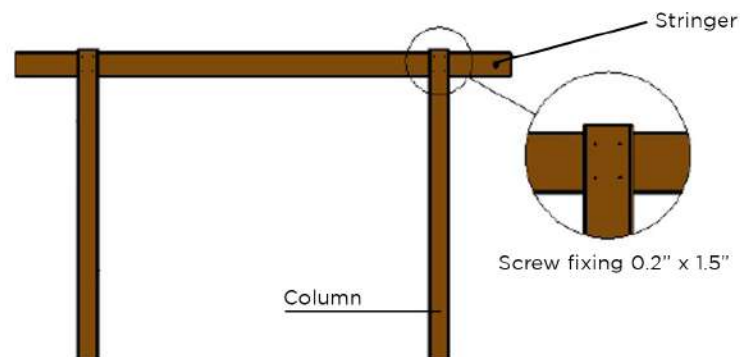

Plastic Ts and 0.2" x 1" DC screws are used when the column matches the same size as the stringer.

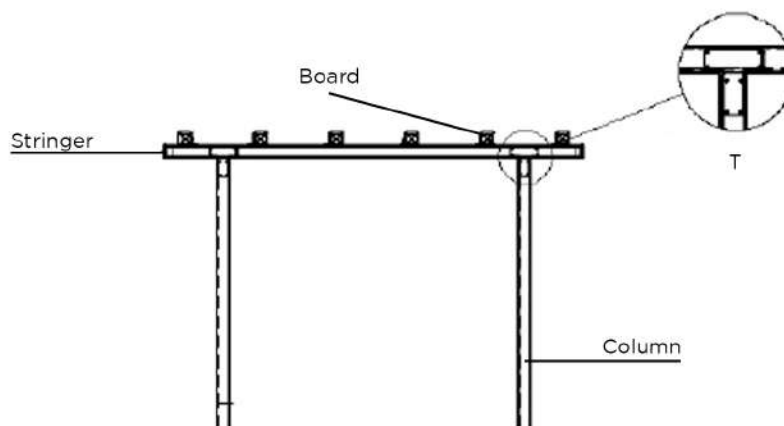

### 3) Boards

For the boards you can use the profile 3.5" x 3.5", 5" x 5" or 6" x 2.5", depending on the customer. To quantify the size of the boards on the pergola, the board's eaves must be equal to the stringers eaves, as shown in the image.

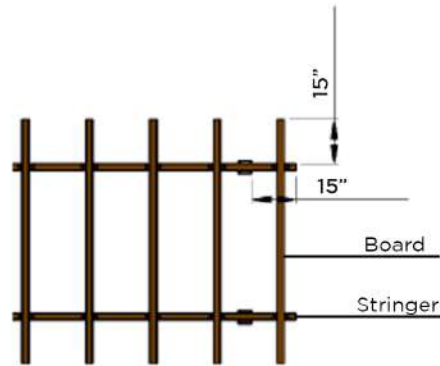

In order to quantify how many stringers will be used on the deck, you must leave a distance of 4" to 11" at the beginning and end of the stringer, as in the image below, and the first board usually has a distance of 4" to 11" from the beginning to the end of the stringer, and the distance between boards can be approximately 19" or according to the customer's taste.

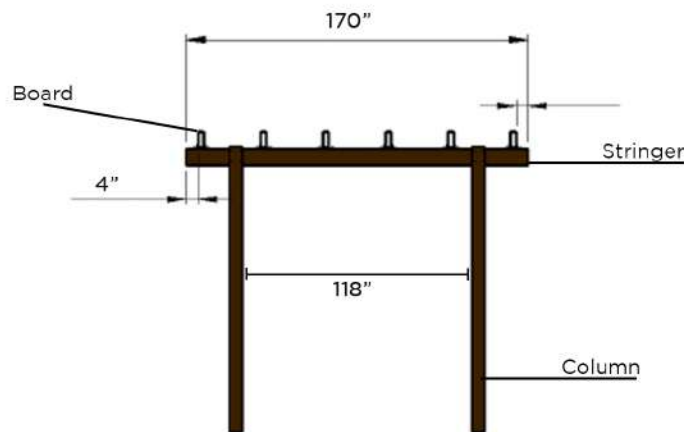

The 3.5" x 3.5", 5" x 5" and 6" x 2.5" boards are fixed to the stringers by means of metal angles with plastic finishing and 0.1" x 1" screws.



Metal corner with plastic finishing

To finish the tips of the profiles of the stringers and boards, applied lids are used.



Applied lid  
3.5" x 3.5"/5" x 5"



Applied lid  
6" x 2.5"



A company by:



[www.inbrasil.ind.br](http://www.inbrasil.ind.br)  
+55 042 3135-5000

[www.foruseco.com](http://www.foruseco.com)  
1-561-774 0707